

OD215 1200 Desk



Please follow these Assembly Instructions.

This will save you time, make assembly easier and prevent possible damage to your new Desk. Assistance may be required for some assembly procedures. Correct assembly is your responsibility.

We recommend that the unit is assembled on a soft surface such as carpet.

Please record your serial number in the space provided below and retain this manual for future reference.

Serial No



For warranty registration and information please go to
www.jasperj.co.nz



Unpack & Identify Parts

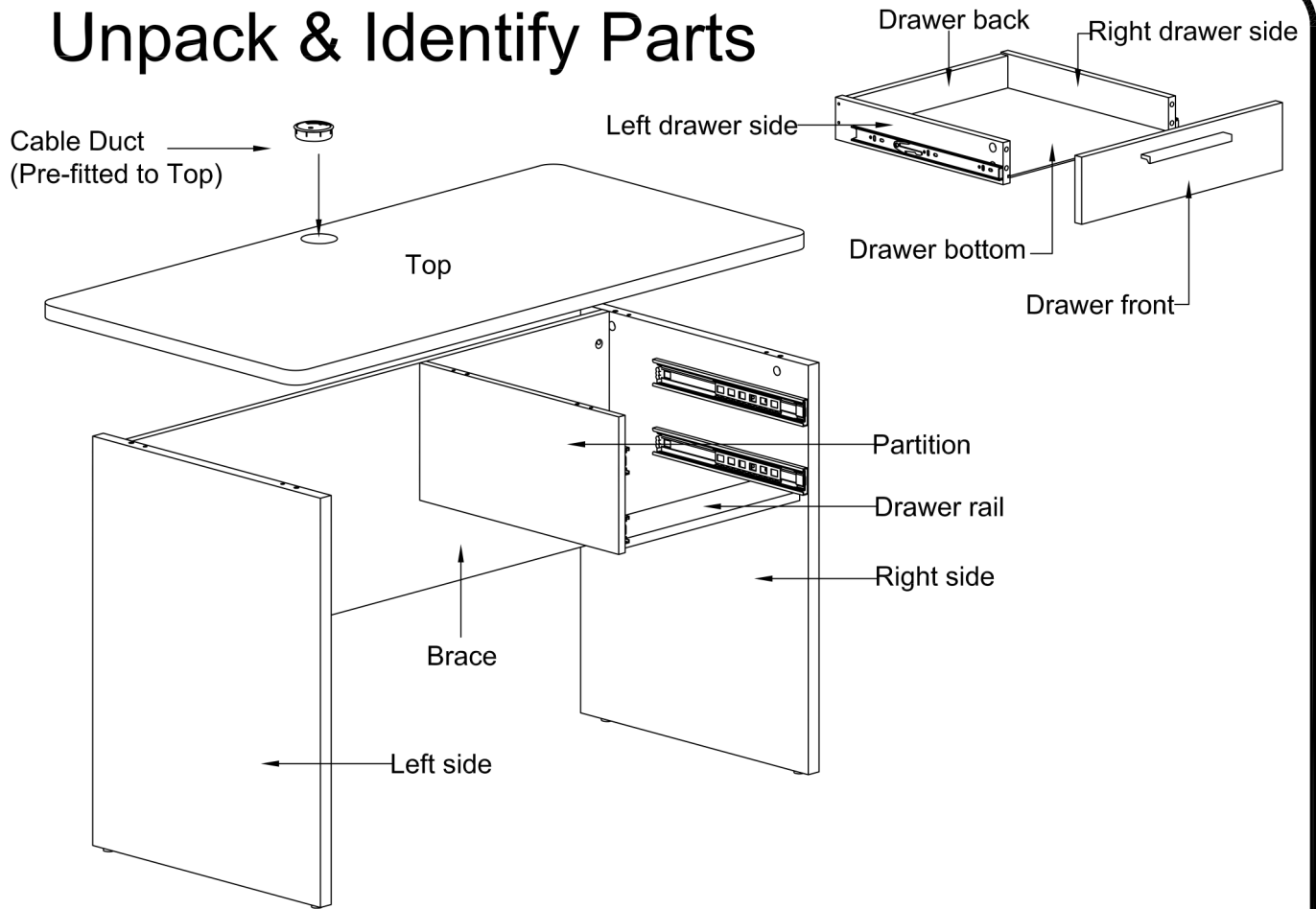

AOD2150B7 carton contents

Part Description	Quantity	Part Number	Part Description	Quantity	Part Number
		Beech			Beech
Top	1	IOD2150B701	Drawer front	1	IOD2150B707
Left side	1	IOD2150B702	Left drawer side	1	IOD2150B708
Right side	1	IOD2150B703	Right drawer side	1	IOD2150B709
Partition	1	IOD2150B704	Drawer back	1	IOD2150B710
Brace	1	IOD2150B705	Drawer bottom	1	IOD2150B711
Drawer rail	1	IOD2150B706	Hardware pack	1	IOD2150HPA0

Tool required

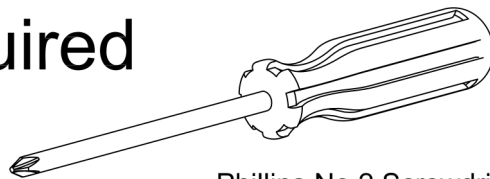

Phillips No.2 Screwdriver or a
Phillips No.2 Pozi drive

Customer Service

0800 450 314

To request spare parts, please provide the details in step one - six.

1. Model number of unit purchased
2. Proof of purchase
3. Description of missing part
4. Part number of missing part
5. Quantity of missing part
6. Serial number of the unit

Post request to.

OR

Scan and take photos
of any damaged parts



Before requesting spare parts, please ensure that you have checked your packaging and used the correct hardware at each step.

JasperJ helpdesk
P.O. Box 47130,
Ponsonby
Auckland 1144

customerservice@jasperj.co.nz



JASPER J

Hardware contents: IOD2150HPA0

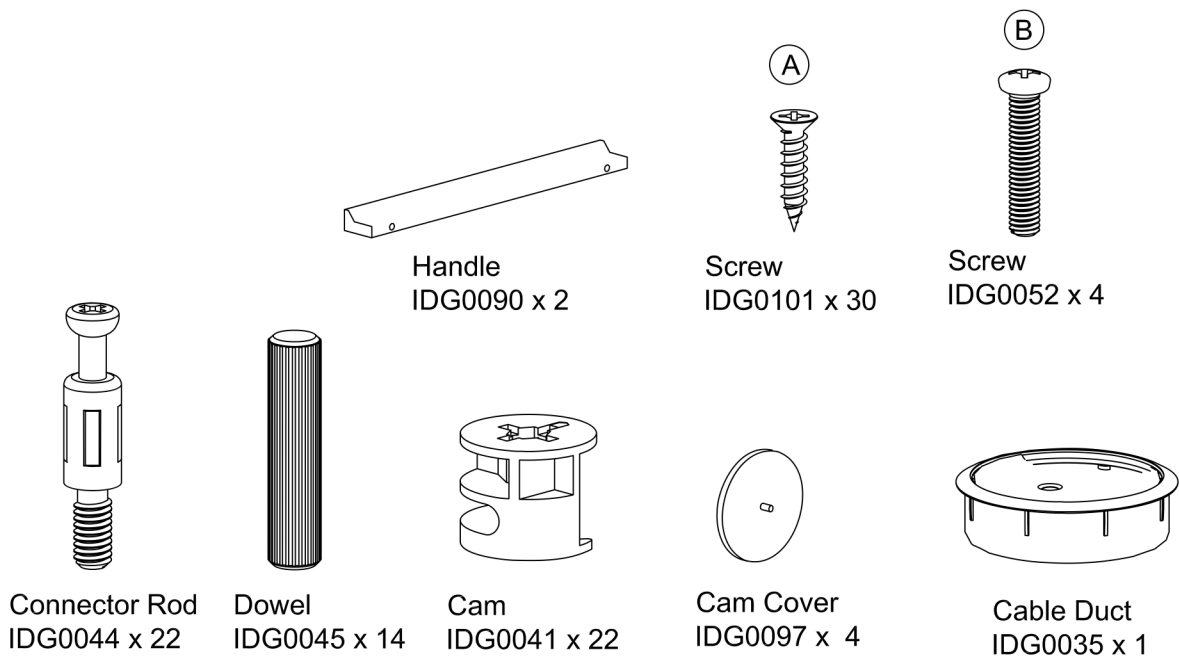

Step 1 Prepare panels

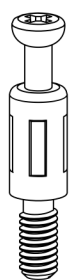

x 8

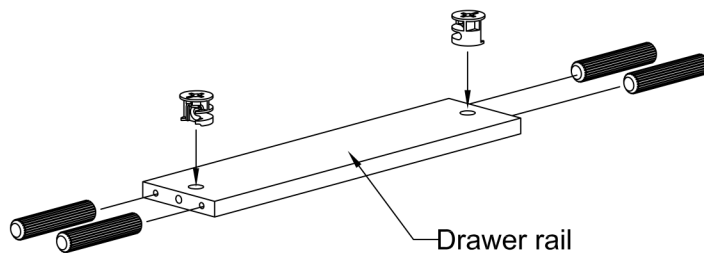

Cam fitting detail

HINT When inserting Cam, ensure arrowhead on Cam points to the edge of hole on panel

Arrowhead

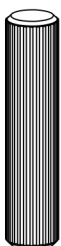

x 6

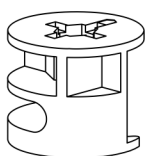
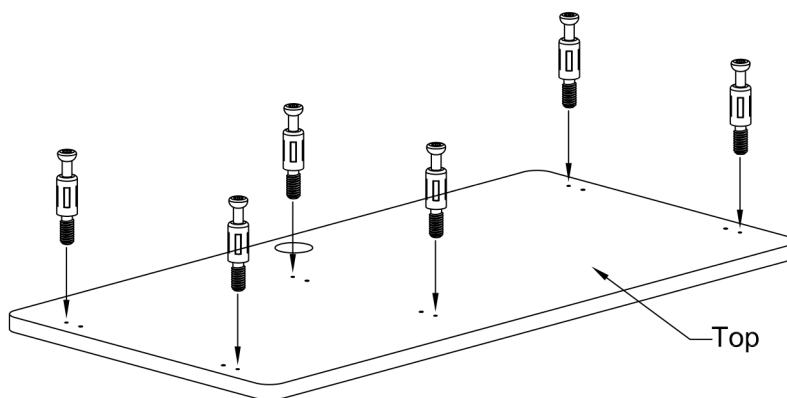

x 4

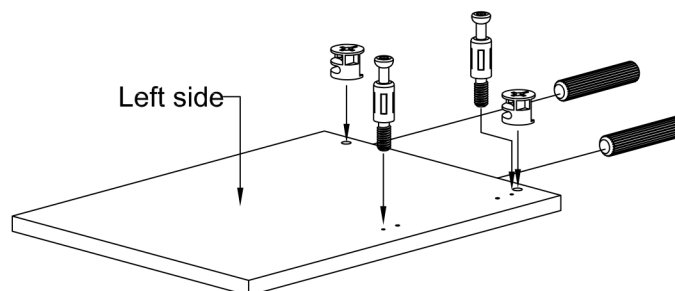

Step 2 Prepare Right side & Partition

(A)



x 8

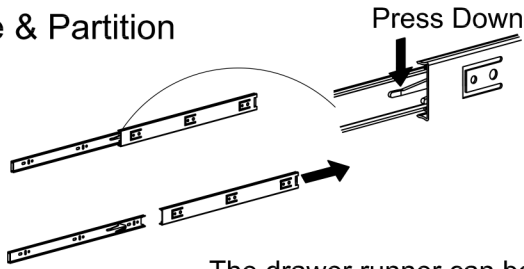

The drawer runner can be detached after depressing the plastic retaining clip.



x 4

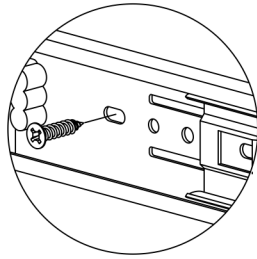

(A)

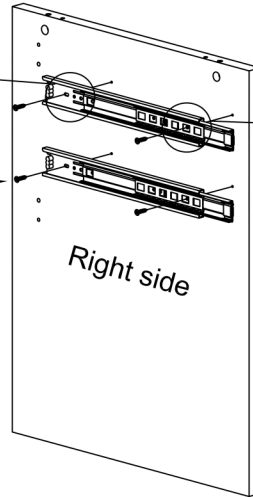

Right side

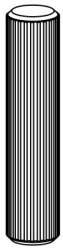
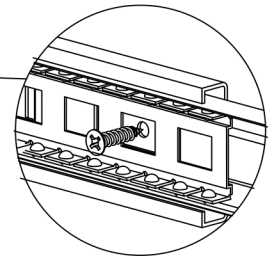

x 6

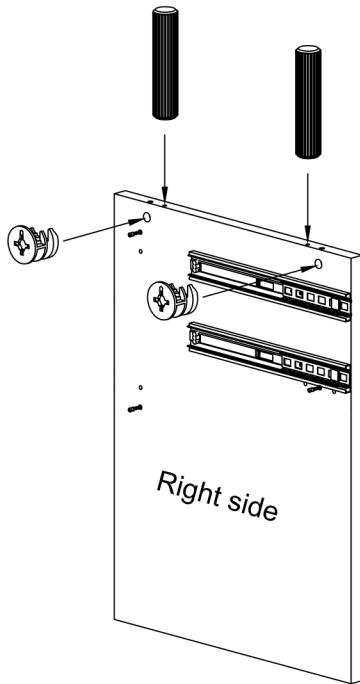

Right side

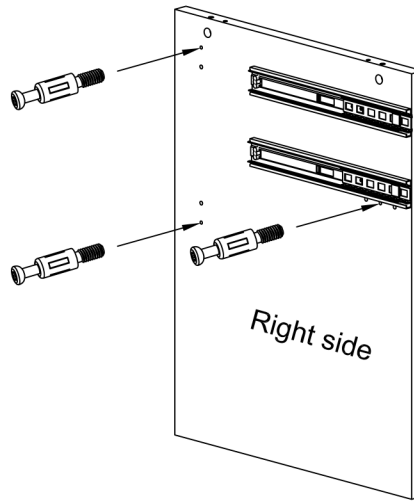

Right side

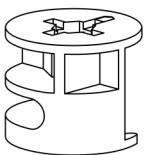

x 4

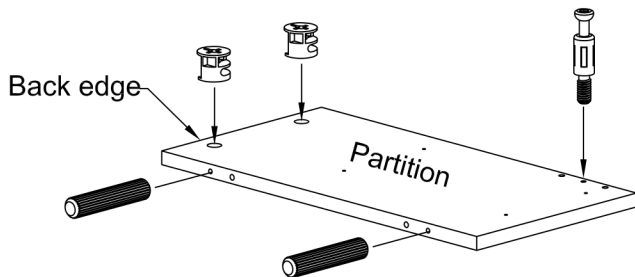

Back edge

Partition

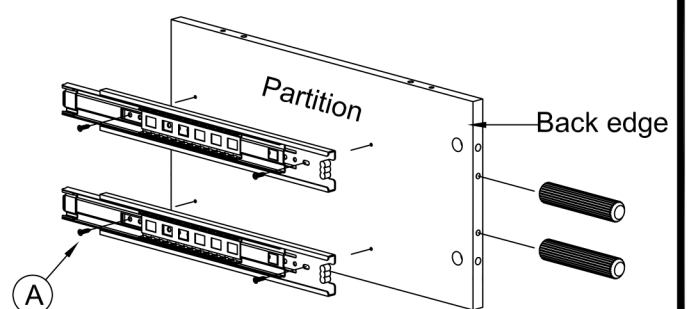

Back edge

Partition

(A)

Step 3 Prepare Brace

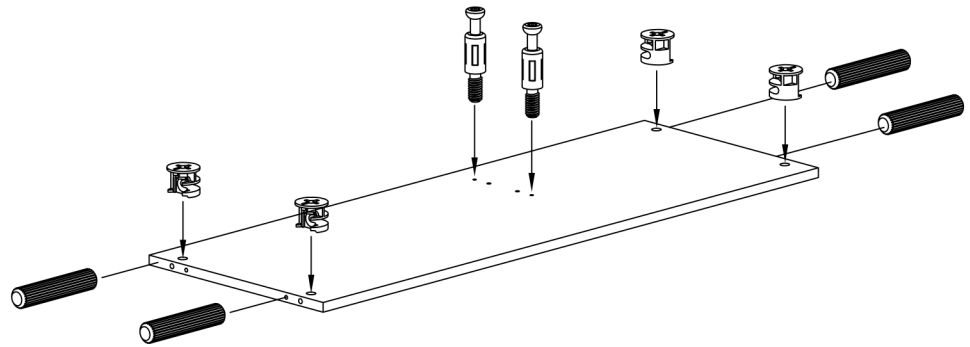
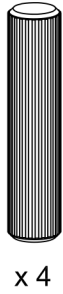
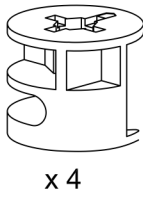

Step 4

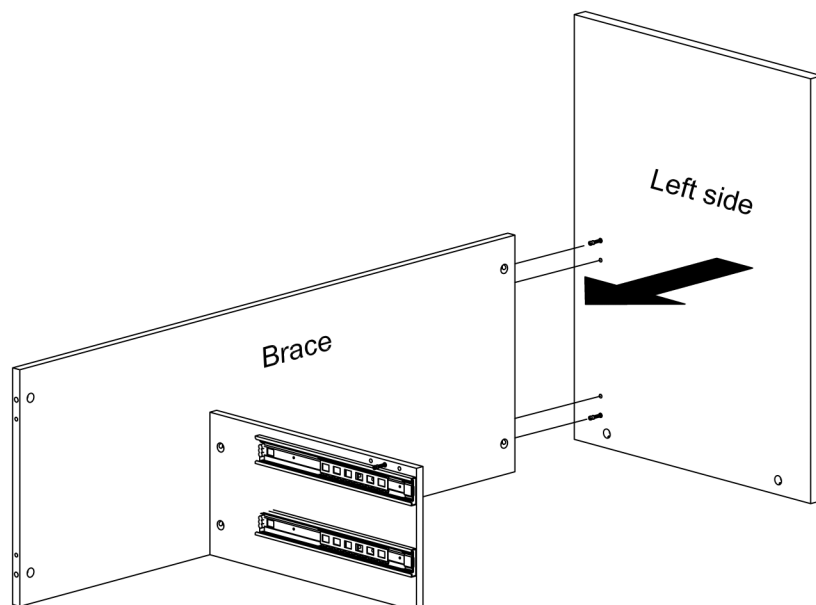
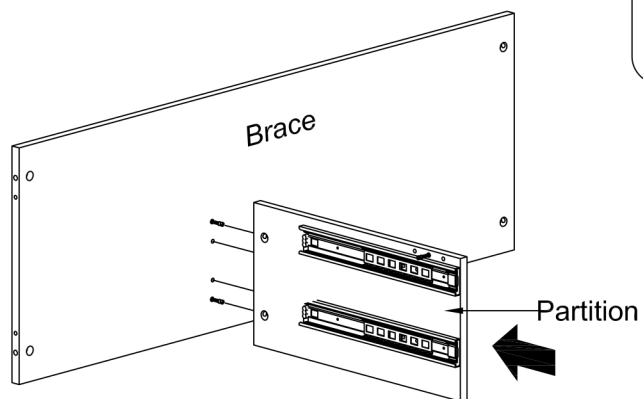

Step 5

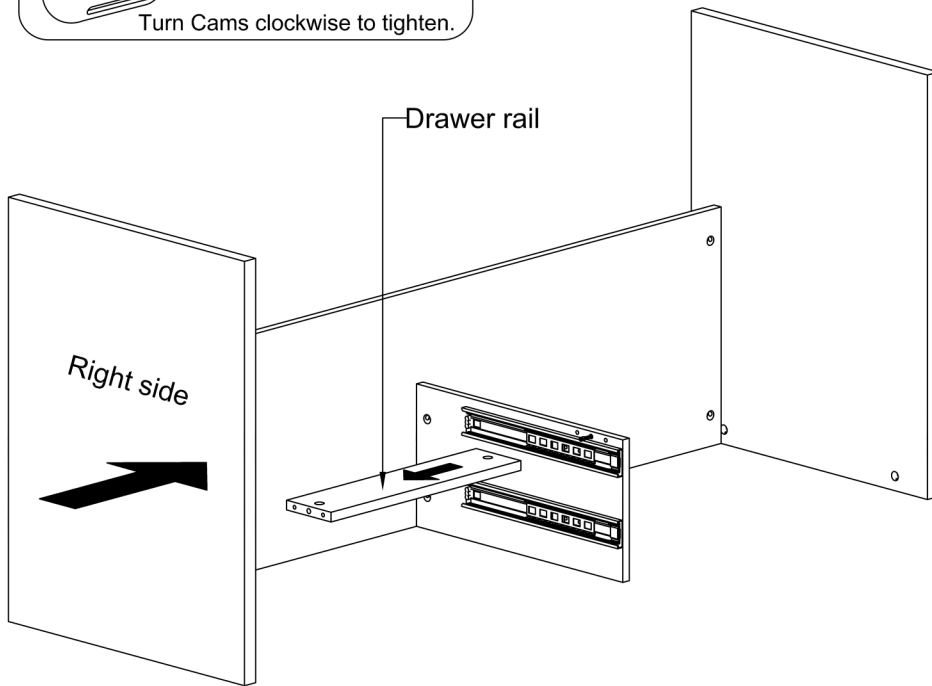
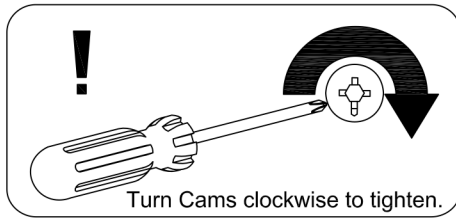

⚠ Assistance may be required for this step.

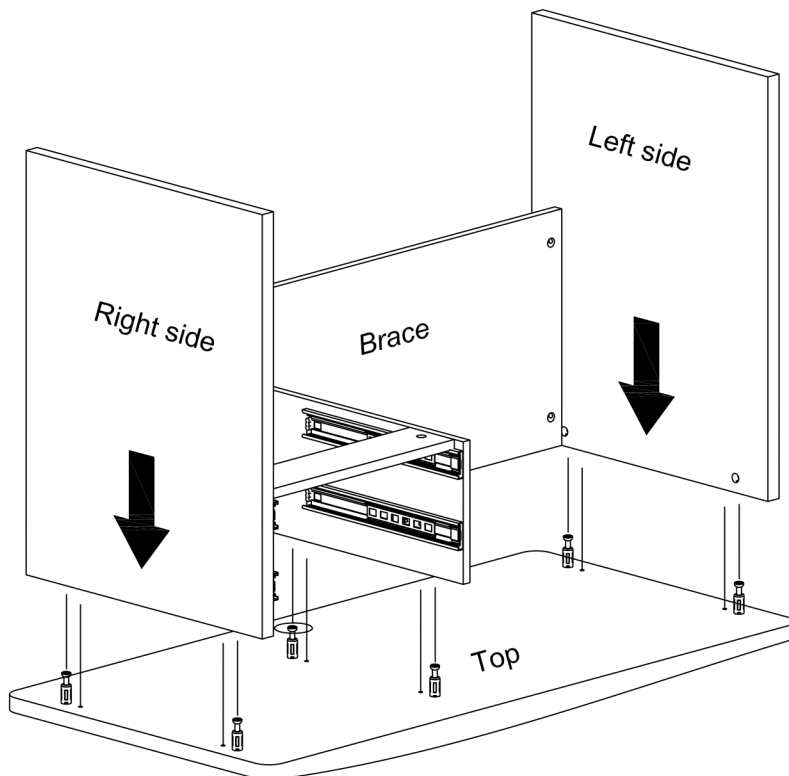

Step 6 Prepare & assemble Drawer components

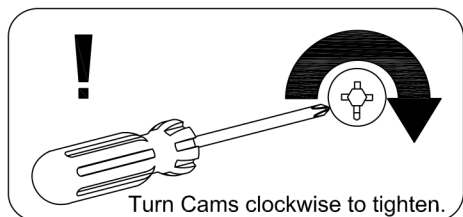

x 8

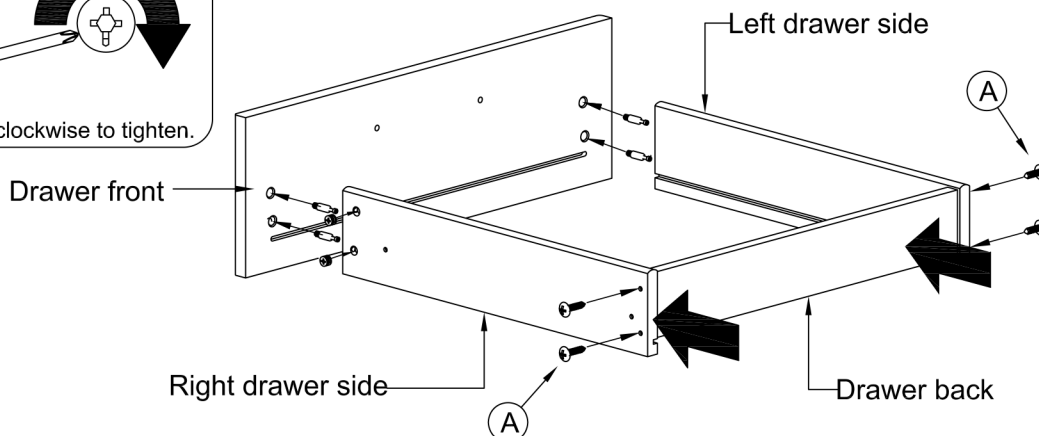

Secure the small drawer sides to the drawer back as shown
Screw two connector rods into holes in drawer front as shown above.
Insert cams into each drawer side as shown.
Fasten the drawer sides to the front by tightening the cams in clockwise direction.

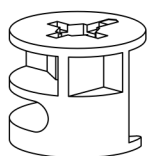

x 8



x 22

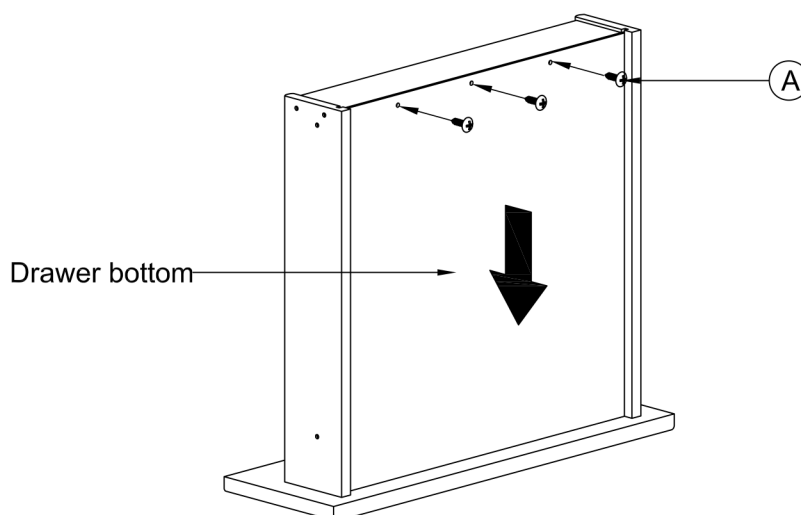

Slide the drawer bottom into the drawer sides and secure it using 3 screws as shown above.

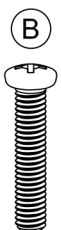

x 4

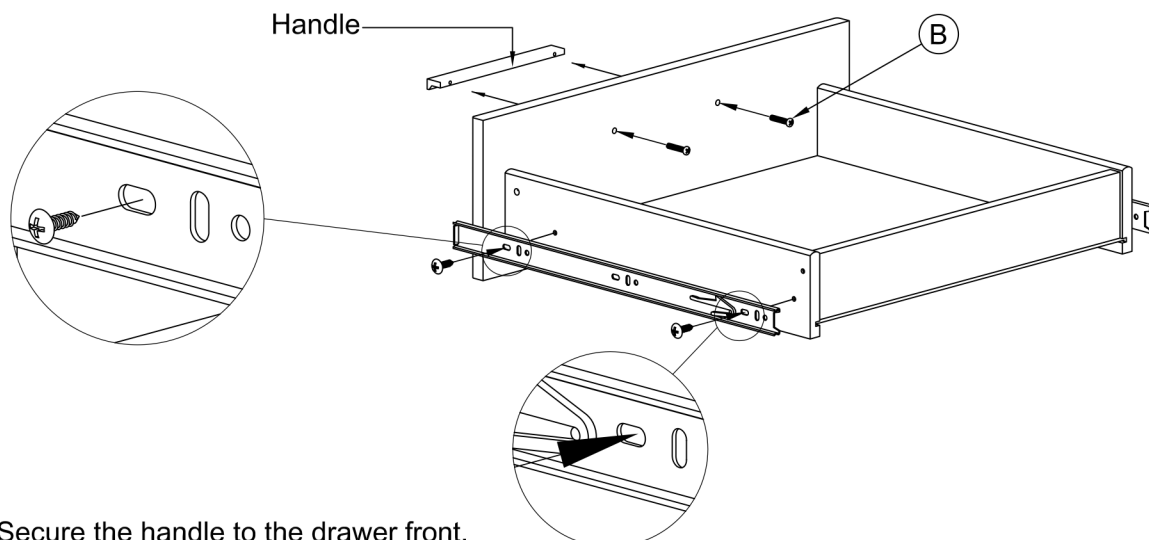

Secure the handle to the drawer front.
Secure the runners to the drawer sides as shown. Use the holes indicated above.

Step 7 Fit Drawers to Desk

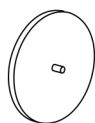

x 4

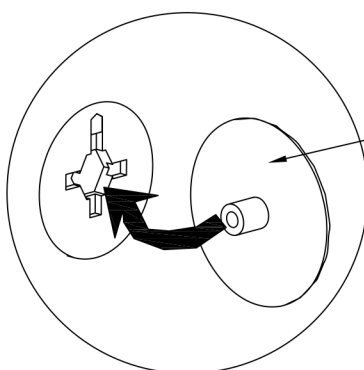

Press fit Cover caps over Cams as shown below

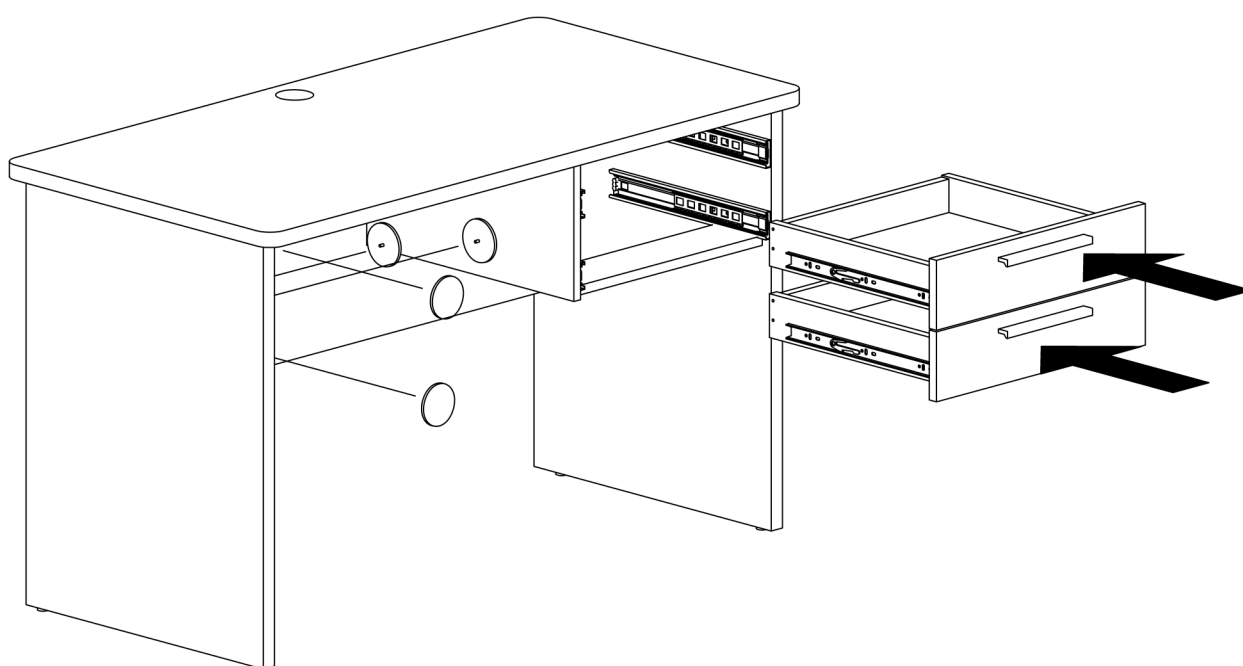

Congratulations. You have now completed the assembly of your new Desk.

CAUTION: We recommend that all contents stored in or on this item of furniture be removed before shifting it. The Manufacturer will not be held liable for damage caused when furniture is shifted without first removing its contents. If the furniture is shifted we recommend that it is lifted not dragged.