

Eko Workstation

Assembly Instructions

Tools Required: Powered screwdriver.

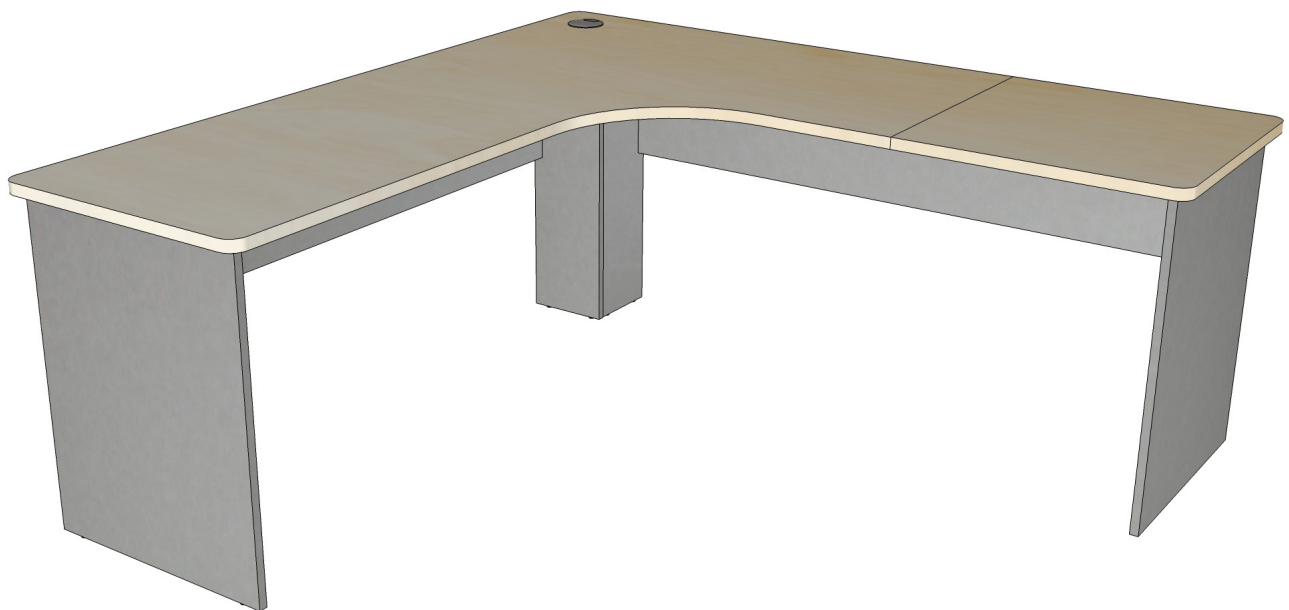

Assembly Instructions

- To prevent possible scratches or damage, assemble the desk upside down on a soft surface such as a blanket, carpet or packaging.
- Attach Leg to the top assembly by using bolts, spring washer, flat washer. Tighten using the allen wrench.

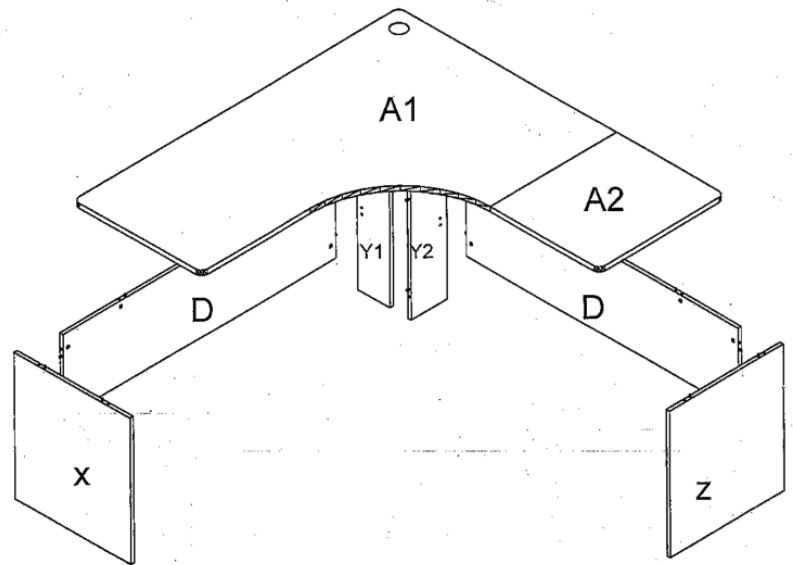

Pre-installed Parts



ⓐ5 Cam

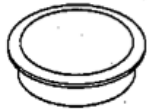

ⓐ1 Cable Port



ⓐ1 6*35 Cam Bolt-22



ⓐ1 8*30 Dowel Pin-18



ⓐ2 (1/2") Cam Cover-22



ⓐ5 6*12 Screw-16



ⓐ1 4*16 Screw-32



ⓐ3 200*60 Connector-2



ⓐ4 6*100 Connector-2

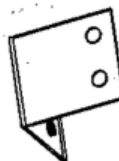

ⓐ1 Bracket-8



ⓐ9 Spanner-1

Step 1

Insert dowel pins (d1) into panel D. Insert cam bolts (c1) and dowel pins (d1) into panels X, Z, Y1 & Y2, then turn the panel Y around 180° and insert cam bolts (c1) into panel Y1.

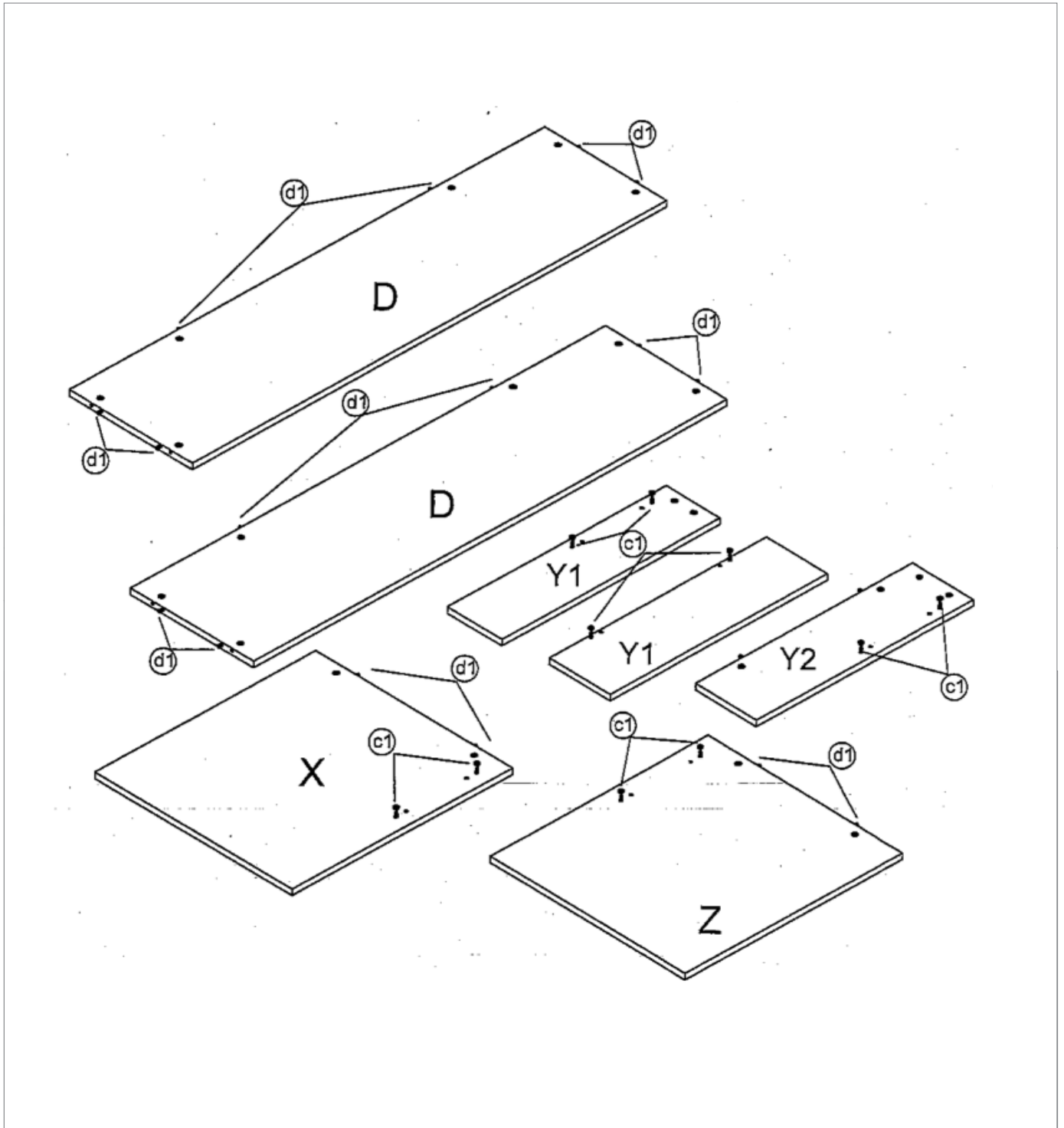

Step 2

Insert cam bolts (c1) into panel A1 and A2.

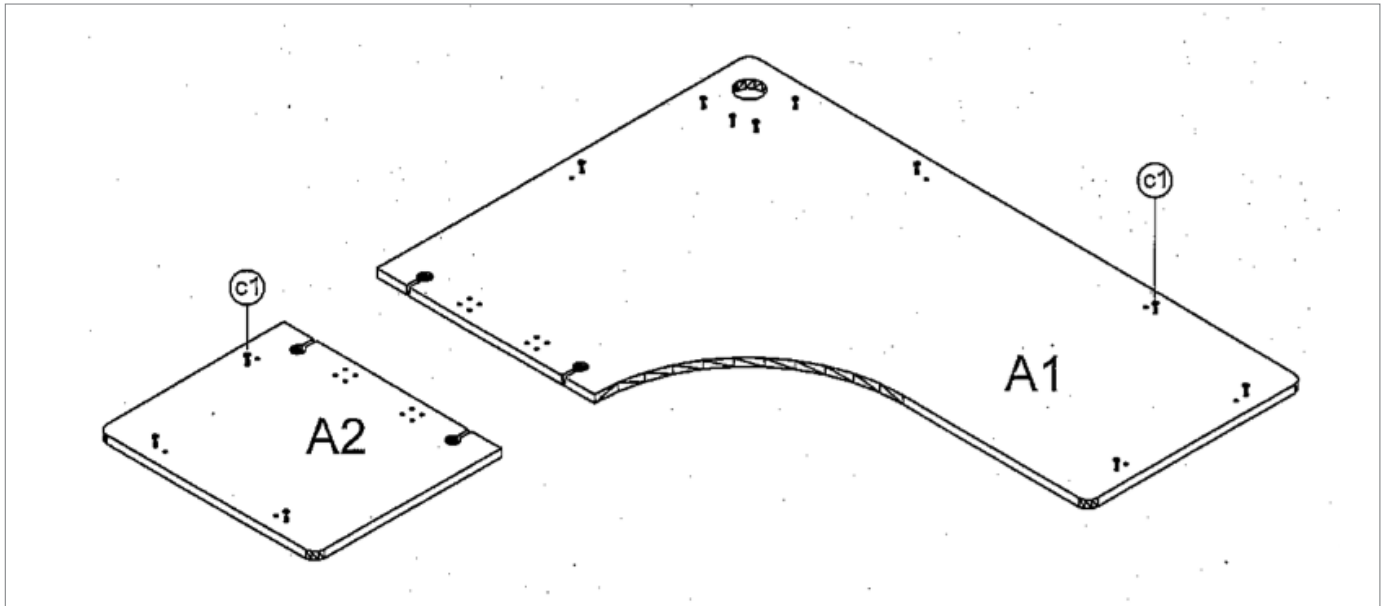

Step 3

Fix cams on panel Y2 into cam bolts (c1) on panel Y1 and fully tighten.

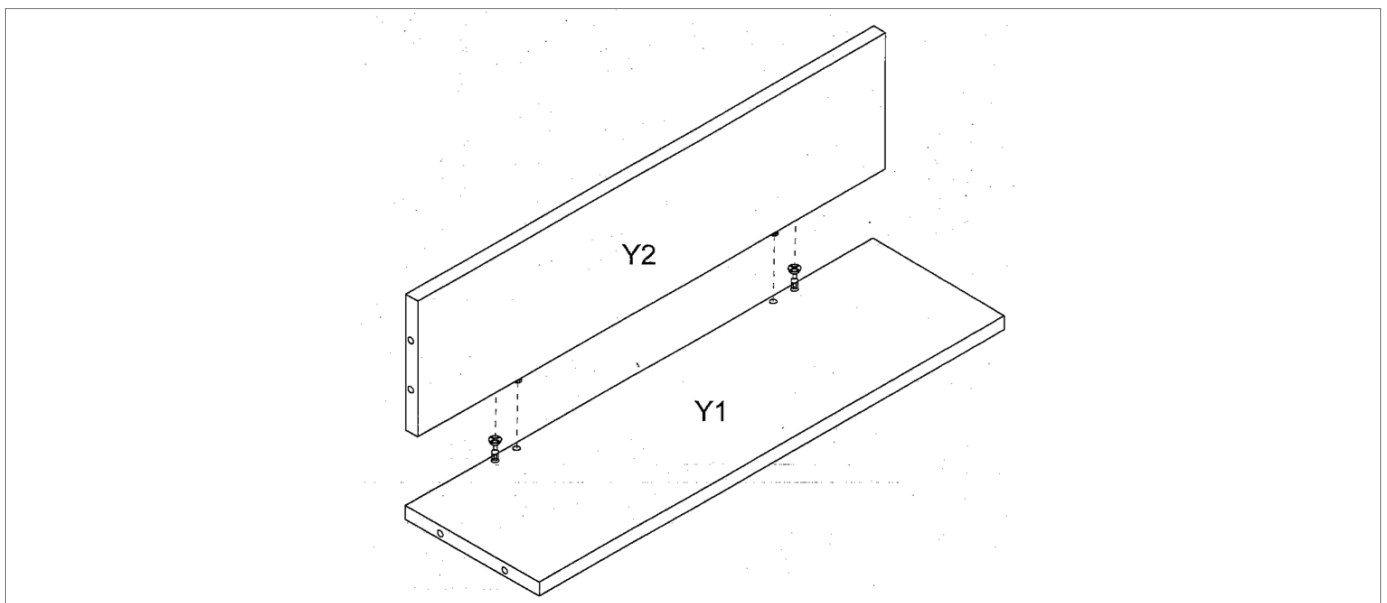

Step 4

Fix cams on panel D into cam bolts (c1) on panels Z and Y2 and fully tighten.

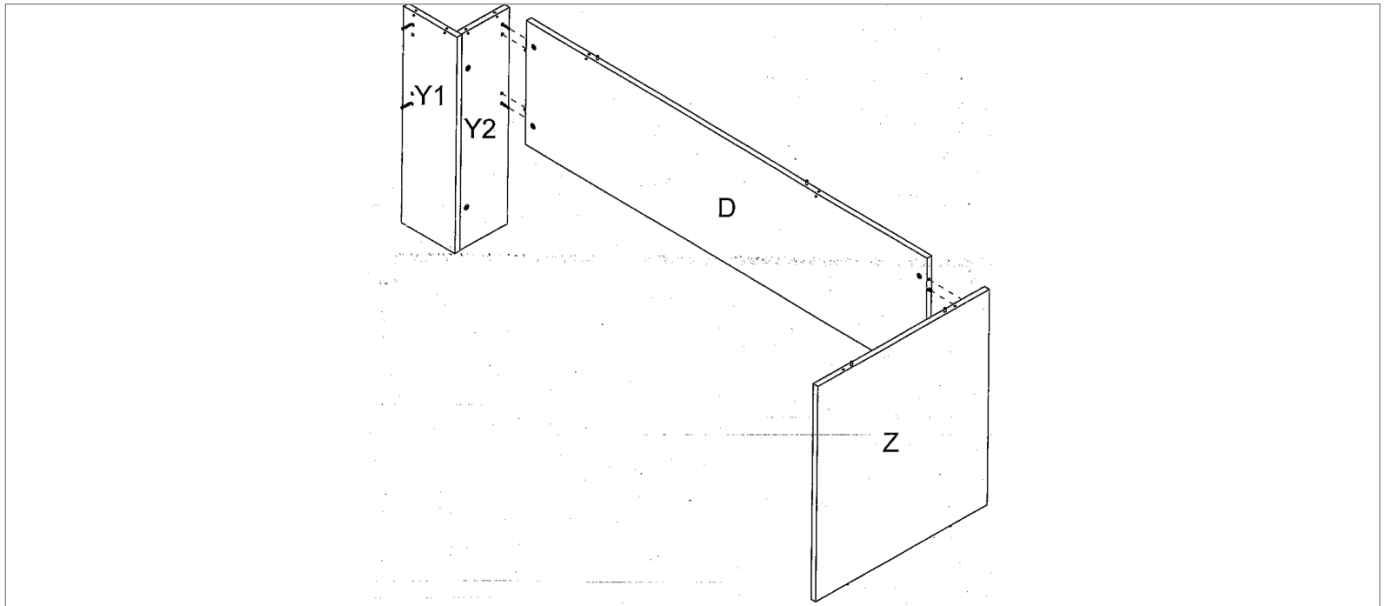

Step 5

Fix cams on panel D into cam bolts (c1) on panels X and Y1 and fully tighten.

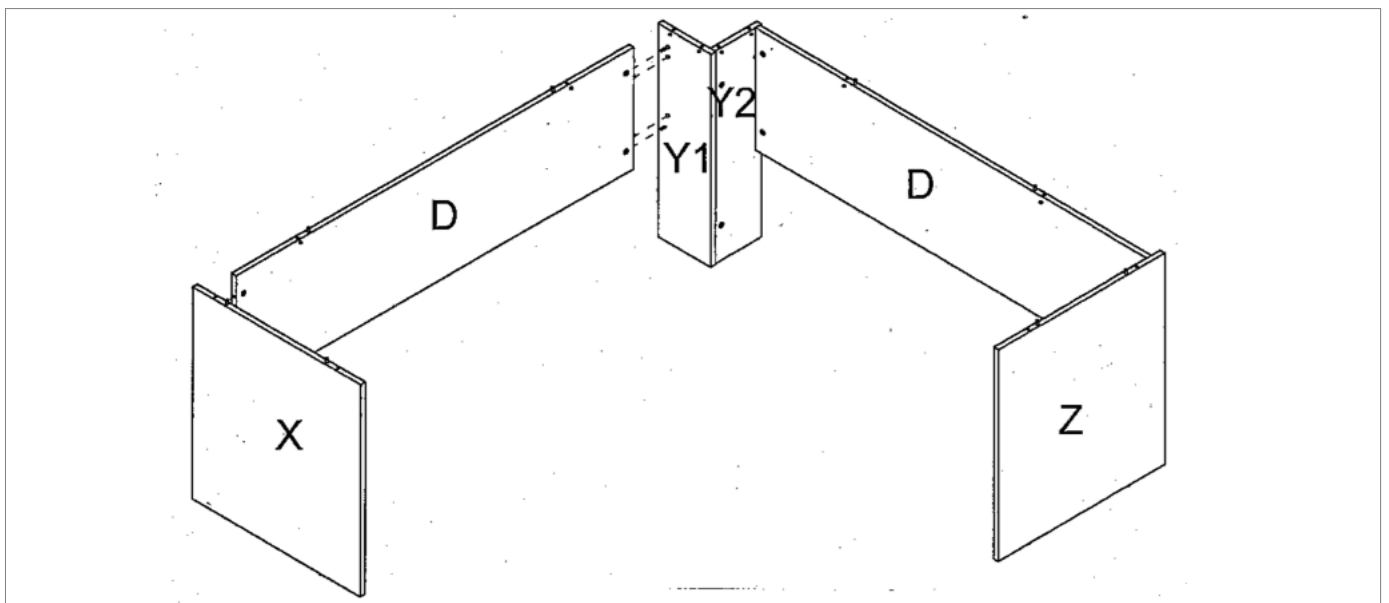

Assembly Instructions

Step 6

Attach connectors (c3) to panels A1 & A2 with screws (s5) and fully tighten. Insert the connector (c4) into panels A1 & A2 and fully tighten. Cover the cam covers (c2) on the top of the cams. Connect panel D and panel X, Y, Z by using bracket (b1).

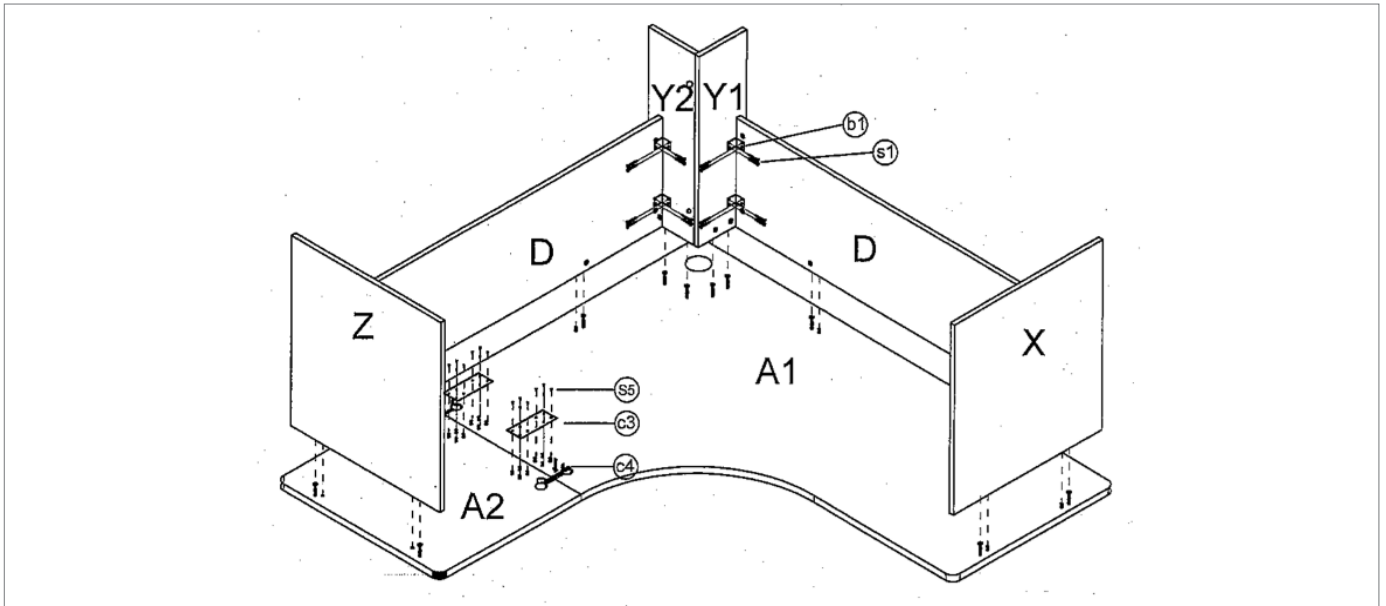

Complete

